

TECHNOLOGY FACT SHEETS

2009-2018



NATIONAL ENGINEERING RESEARCH AND DEVELOPMENT CENTRE
OF SRI LANKA

(Ministry of Science, Technology and Research)



NERD Centre, being the apex body in engineering research and development has developed and adopted many technologies to cater industries, general public and entrepreneurs from grass root level to high end market. These technologies are disseminated & transferred to entrepreneurs aiming of developing their business ventures which are ultimately contribute to GNP of this country.

This booklet contains the summary of the technologies developed by NERD Centre during the period of years 2014 to 2018. All these technologies are available for technology transfer and further information can be obtained from Techno Marketing Department of NERD Centre.

Contents

2009

Industrial Biomass Stove.....	5
Fuel wood chipping machine to produce Gliricidia wood chips	6
Automated Milk Pail Washing Machine	7

2010

Palmyrah Juice Extractor	8
Flap Gate (bottom hinged) for Canals	9

2011

Hand Operated Manioc Slicer	10
Motorized Manioc Slicer	11
Flexible type screw conveyer with twin-screw type distribution system for fuel wood chips	12

2012

Pepper Seed Separator	13
Ferro Cement Foot Bridge	14
Pre-stressed Concrete Foot Bridge	15
Horizontal sub surface flow wetland for domestic wastewater treatment	16

2013

Hydraulic Pre-Stressing Machine.....	17
Crusher for herbal leaves & seeds	18
Fertilizer Applicator for coconut estates	19
Hydraulically operated juice/oil extractor	20
Compact Wastewater Treatment System for Vehicle Service Stations	21

2014

Power Weeder.....	22
Flood Barrier	23

Content

2016

Solar Pinatu Dryer.....	24
Slip Form Wall Construction.....	25
Temperature Controllable bakery Oven.....	26
Domestic Bio Gas Digester working with Kitchen Food waste.....	27
Small scale Cinnamon Oil Distillation Unit.....	28
Composite Hollow Core Slab System for 20ft Span.....	29
Post Tensioned Masonry Retaining Wall System.....	30
“L” Shaped Pre-stressed Concrete Steps.....	31
Hydraulically Operated Compressed Earth Block Machine.....	32
Pre-stressed Concrete Retaining wall panels.....	33
Pre-stressed Concrete Retaining wall System.....	34
Large Scale Hopper machine.....	35
Small Scale Milking Machine.....	36
Foot Operated water Valve.....	37
Compressed Solid Feed Bale Making Machine.....	38
Data Acquisition Model.....	39
Bottom Ash Building Block.....	40
Smoked Fish Processing Unit for SMEs.....	41
Guli Polishing Machine.....	42
Paste making Machine.....	43
Coconut Plucking Pole.....	44
Manual Coconut De-Husker.....	45
Smart Park monitoring System.....	46

Technology Fact Sheet

Technology/Product

Industrial Biomass Stove

Year

2009

Patent Details

Sri Lanka Patent No 15795 (31.12.2013) IPC: F24 B 13/00

Description of technology



Features of industrial stove

Normal fire wood sticks are used as fuel while using other type of biomass such as coconut shells, coconut branches as alternatives. Specifications of the stove are as follows;

- 1.Capacity of cooking pan - 20 Lit.
- 2.Type of wood - Normal firewood sticks
- 3.Fire wood consumption - 4 kg/hr
- 4.Heat controllability - Controllable
- 5.Portability - Portable
- 6.Time taken/batch for treacle making operation – 2 ½ - 3 hrs.

General Information

- 1.Dimensions – 75x100x280 cm
- 2.Total weight – 55 kg
- 3.Fuel consumption – 3.5 kg/hr
- 4.Capacity – 20 litres
- 5.Fuel – Fire wood sticks

Advantages/Benefits

- 1.High efficiency
- 2.Cost effectiveness
- 3.Heat controllability
- 4.Minimum exposure of the operator to heat and smoke
- 5.No contamination of cooking items with ash and soot particles
- 6.Movability -Transportable in a small vehicle (van)

Areas of application

- Cooking in hotels
- water heating
- frying food items
- confectionery industry
- spice processing industry

Contact Details

National Engineering Research and Development Centre, IDB Industrial Estate, Ekala, Ja-Ela, Sri Lanka

Telephone : 0094-11-2236307, 0094-11-2236384 Fax : 0094-11-2233153

E-mail : nerdcentre@nerdc.lk

Web : www.nerdc.lk

Technology Fact Sheet

Technology/Product

Fuel wood chipping machine to produce *Gliricidia* wood chips

Year

2009

Patent Details

Description of technology



Features of the machine

Using this machine fuel wood chip are produced from *Gliricidia* wood sticks. These wood chips are suitable to apply for generating heat for tea drying using the mechanical feeding system developed by NERDC

General Information

- 1.Capacity of the chipping machine: 800 kg/hr
- 2.Power requirement: 10HP, 3phase
- 3.Designed for *Gliricidia* wood sticks
- 4.Size of wood sticks that can be processed: Diameter< 50mm
- 5.Diameter of the cutting wheel: 300mm

Advantages/Benefits

1. When comparison to electric saw type cutter, cutting losses are minimum
2. Easy and self- feeding

Areas of application

- Tea drying

Contact Details

National Engineering Research and Development Centre, IDB Industrial Estate, Ekala, Ja-Ela, Sri Lanka

Telephone : 0094-11-2236307, 0094-11-2236384 Fax : 0094-11-2233153

E-mail : nerdcentre@nerdc.lk

Web : www.nerdc.lk

Technology Fact Sheet

Technology/Product

Automated Milk Pail Washing Machine

Year

2009

Patent Details

Description of technology

Features of the Machine

This Automated machine use to milk collecting pails washing process in milk collecting centres. Specifications of the machine are as follows;

1. Capacity of washing pail - 40 Liter.
- 2.Type of pail -Aluminium / Stainless steel
- 3.Energy consumption - 0.4 kWh
- 4.Control system - Operator panel with PLC controlled
- 5.Portability - Movable (Caster wheel)
- 6.Washing time-30 Seconds per pail (Internal and external surfaces)

General Information

- 1.Dimensions – 2mx 0.75mx1m
- 2.Total weight – 75 kg
- 3.Washing method – Power brush with liquid detergent
- 4.Water requirement – 6 liters per pail
- 5.Detre gent requirement – 2 to 3 ml per pail

Advantages/Benefits

- 1.Less washing effort
- 2.Save washing time
- 3.Uniform washing process
- 4.No pail damage
- 5.less detergent usage
- 6.Washing water collecting facility
- 7.Less electricity consumption
- 8.Easy operation
- 9.Better Water saving

Areas of application

- Milk processing industries
- Fresh milk collecting centres



Contact Details

National Engineering Research and Development Centre, IDB Industrial Estate, Ekala, Ja-Ela, Sri Lanka

Telephone : 0094-11-2236307, 0094-11-2236384 Fax : 0094-11-2233153

E-mail : nerdcentre@nerdc.lk

Web : www.nerdc.lk

Technology Fact Sheet

Technology/Product Palmyrah Juice Extractor

Year

2010

Patent Details

Application Filed

Description of technology



Features of Palmyrah Juice Extractor

Palmyrah juice extractor was designed to extract Palmyrah juice within short period of time.

Power Requirement – 1hp, Single Phase

Holding Capacity – 20-25nuts (25kg)

Operating Time – 25-30min

General Information

1. Dimensions – 815x620x930 mm (LxWxH)
2. Total weight –50kg

Advantages/Benefits

1. Less labour requirement
2. Easy & efficient method
3. Hygienic method

Areas of application

Palmyrah industry

Contact Details

National Engineering Research and Development Centre, IDB Industrial Estate, Ekala, Ja-Ela, Sri Lanka

Telephone : 0094-11-2236307, 0094-11-2236384 Fax : 0094-11-2233153

E-mail : nerdcentre@nerdc.lk

Web : www.nerdc.lk

Technology Fact Sheet

Technology/Product

Flap Gate (bottom hinged) for Canals

Year

2010

Patent Details

-

Description of technology

Features of Flap Gate (bottom hinged) for Canals

The gate is hinged at the bottom, opening and closing is done by cables attached to the top end of the gate. Cables are opened by manually/electrically.

General Information

This water regulating gate provides a method of maintaining the required head in upstream almost independent of up stream flow. Also this could be easily released the floods in rainy season.

The existing lifting type gates are meant to release the required water from storage, and it is not suitable for canals.

The flap gates also could be used in sea end of canals made for drainage purposes to prevent salt water intrusion while releasing the floods.

Advantages

Special advantages over lifting type gates

01. Upstream head Could be maintained as required
02. Quick flood release without blocking of canal by debris
03. Canals bed erosion less
04. Could be automated easily according to various hydrological requirements

Area of Application

1. In canals related to Department of Agrarian Development
2. In canals related to department of irrigation.



Contact Details

National Engineering Research and Development Centre, IDB Industrial Estate, Ekala, Ja-Ela, Sri Lanka

Telephone : 0094-11-2236307, 0094-11-2236384 Fax : 0094-11-2233153

E-mail : nerdcentre@nerdc.lk

Web : www.nerdc.lk

Technology Fact Sheet

Technology/Product

Hand Operated Manioc Slicer

Year

2011

Patent Details

Description of technology

Hand operated Manioc Slicer



Fried manioc chips are becoming popular snack food among the others and producing such foods now is carried out as a cottage industry since it has high demand at the market place.

Since there is a high demand for an equipment to make slicing from manioc, a hand operated slicer was developed and it can be used not only for slicing manioc but also for other similar vegetables.

General Information

Slicing capacity	: 10 kg/hr of manioc
Slicing efficiency	: 80%
Rotation of the disc	: manual
RPM of slicer shaft	:130
Thickness of slices	:0.6 – 1.1 mm
Overall size(HxWxB)	:562mmx250mmx61 mm

Advantages/Benefits

01. Ability to slice to an uniform thickness
02. Increase of production capacity.
03. Portable
04. Operated by single person
05. Easy operation & maintenance

Areas of application

Manioc slicing
Vegetable slicing like brinjals, Bitter guard, potatoes etc.

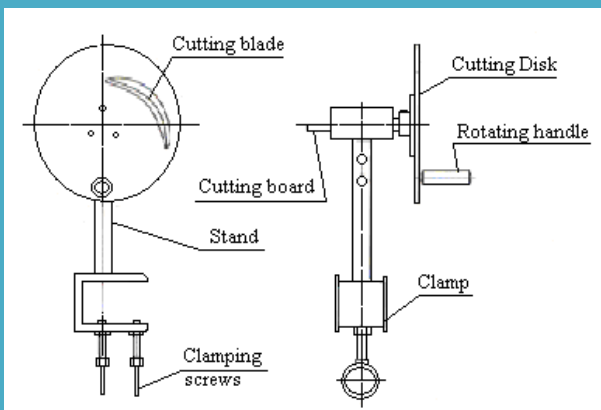

Contact Details

National Engineering Research and Development Centre, IDB Industrial Estate, Ekala, Ja-Ela, Sri Lanka

Telephone : 0094-11-2236307, 0094-11-2236384 Fax : 0094-11-2233153

E-mail : nerdcentre@nerdc.lk

Web : www.nerdc.lk

Technology Fact Sheet

Technology/Product

Motorized Manioc Slicer

Year

2011

Patent Details

Description of technology



Features of Motorized Manioc Slicer

The objective of developing this technology is to cut few, identified type of vegetable and fruits to a desirable size and thickness.

Motorized manioc slicer has a great demand among SMEs as it is capable of using for other similar applications such as slicing of vegetables (carrot, brinjals, lotus roots etc.) ginger and onions. Normally the machine has the capacity of 100 kg/hr slicing manioc to a thickness of 0.8 mm with the facility

Specification of the machine

Motor Capacity - 180 W

Slicing Capacity - 40 – 50 kg/hr

Power Requirement - 230 v/ 50 Hz (Single phase supply)

General Information

Weight - 16.5 kg

Size (LxWxH) - 60 cm x 38 x cm x 46 cm

Advantages/Benefits

1. Ability to slice to an uniform thickness.
2. Ability of changing of slice thickness as required.
3. High production rate.
4. Portable.
5. Operated by single person.
6. Easy operation & maintenance.

Areas of application

- Manioc slicing
- Vegetable slicing like brinjal, Bitter guard, potatoes and lotus roots etc.
- Ginger slicing

Contact Details

National Engineering Research and Development Centre, IDB Industrial Estate, Ekala, Ja-Ela, Sri Lanka

Telephone : 0094-11-2236307, 0094-11-2236384 Fax : 0094-11-2233153

E-mail : nerdcentre@nerdc.lk

Web : www.nerdc.lk

Technology Fact Sheet

Technology/Product

Flexible type screw conveyor with twin-screw type distribution system for fuel wood chips

Year

2011

Patent Details

Sri Lanka Patent No 16444, 04/06/2014; IPC: B 65G 33/00

Description of technology

Features of this technology

Using this technology fuel wood chips are feed mechanically in to the tea drying furnace and it replaces conventional manual feeding of wood logs or split wood logs to generate heat in tea drying.

Specifications of the machine are as follows;

1. Power requirement of the screw conveyor: 1.1kW, 3 phase
2. Operation: By manually setting the speed of the conveyor through Variable Speed Drive
3. Required size of fuel wood chips: 18-60mm(\varnothing)x75 X 115(L)
4. Loading of wood chips: Manually, in 20 minutes time intervals.

General Information

1. Motor of the feeding system is driven through a variable speed drive so that the speed is controlled as per the requirement.
2. Fuel wood should be available in the form of chips.
3. Fuel wood with moisture content < 20% (wet basis) is preferred.

Advantages/Benefits

1. Can be retrofitted to existing wood firing furnaces
2. *Gliricidia* fuel wood can be used for tea drying which make the system sustainable.
3. There is a saving of at least 15% by weight of fuel wood purchased.

Areas of application

- Tea drying

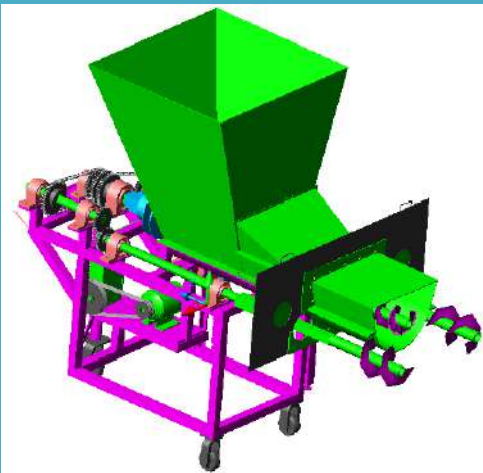

Contact Details

National Engineering Research and Development Centre, IDB Industrial Estate, Ekala, Ja-Ela, Sri Lanka

Telephone : 0094-11-2236307, 0094-11-2236384 Fax : 0094-11-2233153

E-mail : nerdcentre@nerdc.lk

Web : www.nerdc.lk

Technology Fact Sheet

Technology/Product **Pepper Seed Separator**

Year

2012

Patent Details

Filed

Description of technology



Features of Pepper Seed Separator

The Pepper Seed Separator reduces the intensive labour involvement and wastage in manual pepper seed separation process.

Power requirement: 180 W single phase motor/230V/50Hz

Capacity : 200kg/hr

General Information

1. Dimensions – 310x760x890mm (LxWxH)
2. Total weight – 38kg

Advantages/Benefits

1. Continuous operation
2. Low labour requirement
3. Hygienic process
4. Compact machine and less weight
5. Low wastage

Areas of application

Pepper industry

Contact Details

National Engineering Research and Development Centre, IDB Industrial Estate, Ekala, Ja-Ela, Sri Lanka

Telephone : 0094-11-2236307, 0094-11-2236384 Fax : 0094-11-2233153

E-mail : nerdcentre@nerdc.lk

Web : www.nerdc.lk

Technology Fact Sheet

Technology/Product **Ferro Cement Foot Bridge**

Year

2012

Patent Details

Description of technology

Features of Ferro Cement Foot Bridge

Normal Portland cement, sand, 6 mm ϕ mild steel, 10 mm ϕ tor steel, 1" x 1" G18 GI wire mesh and 5 mm ϕ High tensile wires are used as raw materials. Steel hand rails are fixed at the both sides of the bridge. The Ferro cement bridge beams can be cast at site or at a pre-cast yard. Span of the bridge can be extended up to 30'-0" by pre-stressing the Ferro cement bridge beams. Pre-stressed Ferro cement bridge beams have to be cast at pre stressing yard. Specifications of the bridge is as follows;

1. Uses-Pedestrian, Motor bicycle and three wheels.

General Information

1. T-shaped bridge beams- 2 Nos
2. Size of the Beam- 2'-0" x 2'-0"
3. Thickness of the web and flange: 2"
4. Maximum Span- Ferro cement : 20'-0"
Pre- stressed Ferro cement: 30'-0"
5. Width of the bridge: 4'-0" or 5'-0".

Advantages/Benefits

1. Raw materials readily available in the market.
2. Strength/weight ratio is high.
3. Production is simple and require few hand tools
4. No special skill is required
5. Low maintenance cost
6. Less labour involvement
7. Cost effective.

Areas of application

- To cross canals in rural roads and foot paths,
- To replace the unsafe "Edanda",



Contact Details

National Engineering Research and Development Centre, IDB Industrial Estate, Ekala, Ja-Ela, Sri Lanka

Telephone : 0094-11-2236307, 0094-11-2236384 Fax : 0094-11-2233153

E-mail : nerdcentre@nerdc.lk

Web : www.nerdc.lk

Technology Fact Sheet

Technology/Product

Pre-stressed Concrete Foot Bridge

Year

2012

Patent Details

Description of technology



Features of pre-stressed concrete foot bridge

Pre-stressed concrete foot bridge is introduced as an alternative to the “unsafe edanda” to cross canals in rural areas. Features of the pre-stressed concrete foot bridge are as follows;

1. Pre-stressed/ insitu concrete composite deck
2. Heavy duty G.I. Hand rail

General Information

1. Span – 20 to 30 feet
2. Width – 4’-0” to 6’-6”
3. Use –Pedestrian, motorcycle, three-wheeler & land master

Advantages/Benefits

1. Fast construction
2. Cost effectiveness
3. No formwork required
4. Easy handling

Areas of application

- To cross canals in rural roads and foot paths,
- To replace the unsafe “Edanda”,

Contact Details

National Engineering Research and Development Centre, IDB Industrial Estate, Ekala, Ja-Ela, Sri Lanka

Telephone : 0094-11-2236307, 0094-11-2236384 Fax : 0094-11-2233153

E-mail : nerdcentre@nerdc.lk

Web : www.nerdc.lk

Technology Fact Sheet

Technology/Product

Horizontal sub surface flow wetland for domestic wastewater treatment

Year

2012

Patent Details

Description of technology



Design Data

Bed area in a single tank	= 4 m ²
Total bed height	= 750 mm
Head Space	= 100 mm
Water retention height	= 650 mm
Bed length	= 2500 mm
Bed width	= 1600 mm
Porosity	= 0.4
Effluent loading	=100ml/day/m ²
Retention time	=2.6 days

Benefits, to end-users

1. Treated water can be either directly discharged to the environment or use for some domestic applications like gardening.
2. Can be built as a part of the home garden
3. Sustainable system operation and maintenance
4. Inexpensive construction, operation and maintenance cost.

Major Components

1. Common collection tank
2. 4 Nos. of pre-cast concrete tanks
3. Piping and valves
4. Filling media (3/4" metal and 6"x4" rubble)

Wastewater Characteristics

Appearance	: very clear
Odour	: No any
COD	: 90%
BOD	: Below 30 mg/l.
TSS	: 297 mg/l to below 5 mg/l
pH	: 6.5 to 7.5.
Ammonical Nitrogen	: Below the standard limit.

Contact Details

National Engineering Research and Development Centre, IDB Industrial Estate, Ekala, Ja-Ela, Sri Lanka

Telephone : 0094-11-2236307, 0094-11-2236384 Fax : 0094-11-2233153

E-mail : nerdcentre@nerdc.lk

Web : www.nerdc.lk

Technology Fact Sheet

Technology/Product

Hydraulic Pre-Stressing Machine

Year

2011

Patent Details

Description of technology



Features of Pre-Stressing Machine

This machine is designed for pre-stressing of high tensile wires in making pre-stressed concrete beams at pre-stressed concrete yards. The machine facilitates in drawing the wires at desired tensile force with easy fixing and removing of facility. It is capable of pre-stressing of four numbers of wires to a maximum load of 150 kN at a time. The machine consists of two hydraulic rams a power pack with a manually operated valve box. The machine could be moved along the load bearing wall of the pre-stressed concrete yard in order to use this facility at multiple places where the pre-stressing of wires are required. The level of the wires are being pre-stressed could also be varied depending upon the level of the pre-stressed concrete are being laid.

Specification of the machine

Motor Capacity - 3 kW
Power Requirement - Three phase supply

General Information

Weight - 400 kg
Size (LxWxH) - 180 cm x 90 x cm x 210 cm

Advantages/Benefits

01. Ability to apply the required tension to the wire.
02. Easy fixing and dismantling of the wires to be pre-stressed.
03. High productivity.
04. Ability to pre-stressing wires at desired level of the concrete bed.
05. Ability to operate by single person.
06. Easy operation & maintenance.

Areas of application

- Places where the pre-stressed concrete elements are made.

Contact Details

National Engineering Research and Development Centre, IDB Industrial Estate, Ekala, Ja-Ela, Sri Lanka

Telephone : 0094-11-2236307, 0094-11-2236384 Fax : 0094-11-2233153

E-mail : nerdcentre@nerdc.lk

Web : www.nerdc.lk

Technology Fact Sheet

Technology/Product

Crusher for herbal leaves & seeds

Year

2013

Patent Details

Description of technology



Features of Crusher for herbal leaves & seeds

In Ayurvedic sector, machineries are available for large and medium scale medicine preparation, but there are very less number of machineries for small scale medicine preparation for traditional Ayurvedic doctors. According to the requirements of the sector, a crusher was developed as a result of research and field trials carried out by the Dept. of Agricultural Engineering & Post harvest Technology in NERDC. The developed crusher can be used for crushing of herbal leaves and seeds.

Power Requirement : 1hp, Single Phase

Capacity : 15-20 kg of leaves/hr (approximately)

or

35-40kg of seeds/hr (approximately)

General Information

1. Dimensions : 760x620x920mm (LxWxH)

2. Total weight : 54 kg

Advantages/Benefits

1. Portable
2. Can be operated by single person
3. Hygienic process (all medicine contaminated parts are made of food grade stainless steel)
4. Easy to clean & maintain

Areas of application

Ayurvedic industry & food industry

Contact Details

National Engineering Research and Development Centre, IDB Industrial Estate, Ekala, Ja-Ela, Sri Lanka

Telephone : 0094-11-2236307, 0094-11-2236384 Fax : 0094-11-2233153

E-mail : nerdcentre@nerdc.lk

Web : www.nerdc.lk

Technology Fact Sheet

Technology/Product

Fertilizer Applicator for coconut estates

Year

2013

Patent Details

Application Filed

Description of technology



Introduction

Fertilizing of coconut trees is a time consuming and labour intensive task, which has become a problem for coconut estate owners due to the unavailability of human labour. This innovative fertilizer applicator for coconut plantations improves its workability comparing to the cost and absorptivity of fertilizer.

It is an attachment, operates using Power Transmission Output (PTO) of the common two-wheel tractor. That is inbuilt with modified rotavator and fertilizer spreader where the spreader spread fertilizer evenly and the inbuilt rotavator loosen the spread fertilizer soil while cutting of small roots of the palms. This technique is improved the absorption capacity of fertilizer to the palm as in the view of coconut plantation expertise.

General Information

- Application time : Around 2 minutes/palm (Due to conditions of the estate)
- Hopper capacity : 35kg
- Tractor specifications : 12 /6 hp two-wheel tractor

Advantages/Benefits

- Homogeneous spread of fertilizer around the palm tree.
- Ability of applying right quantity of fertilizer.
- Minimize wastage of fertilizer.
- Applying fertilizer within 2 minutes.
- As the machine damages the feeding roots of the palm tree, absorption of fertilizer becomes more efficient.
- Ability to fertilize at least 10 Nos. of palms with one loading.
- More than 50% of financial saving could be achieved.

Areas of application

- Coconut estates
- Palmyra estates

Contact Details

National Engineering Research and Development Centre, IDB Industrial Estate, Ekala, Ja-Ela, Sri Lanka

Telephone : 0094-11-2236307, 0094-11-2236384 Fax : 0094-11-2233153

E-mail : nerdcentre@nerdc.lk

Web : www.nerdc.lk

Technology Fact Sheet

Technology/Product

Hydraulically operated juice/oil extractor

Year

2013

Patent Details

Description of technology



Features of Hydraulically operated juice/oil extractor

In Ayurvedic sector, machineries are available for large and medium scale medicine preparation, but there are very less number of machineries for small scale medicine preparation for traditional Ayurvedic doctors. According to the requirements of the sector, a hydraulic jack operated juice/oil extractor was developed as a result of research and field trials carried out by the Dept. of Agricultural Engineering & Postharvest Technology in NERDC.

Jack operated juice/oil extractor can be used to extract juice/oil from the crushed herbal leaves/seeds and to extract remaining oil from residual sludge (kalka).

- Operated using 3 ton hydraulic jack
- Capacity - 3kg of crushed leaves/batch (approximately) or 1kg of crushed seeds/batch (approximately)

General Information

1. Dimensions : 370x280x1360mm (LxWxH)
2. Total weight : 52 kg

Advantages/Benefits

1. Portable
2. Can be operated by single person
3. Hygienic process (all medicine contaminated parts are made of food grade stainless steel)
4. Easy to clean & maintain

Areas of application

Ayurvedic industry

Contact Details

National Engineering Research and Development Centre, IDB Industrial Estate, Ekala, Ja-Ela, Sri Lanka

Telephone : 0094-11-2236307, 0094-11-2236384 Fax : 0094-11-2233153

E-mail : nerdcentre@nerdc.lk

Web : www.nerdc.lk

Technology Fact Sheet

Technology/Product

Compact Wastewater Treatment System for Vehicle Service Stations

Year

2013

Patent Details

Description of technology



Plant Operation

Service station requires a initial collecting tank to collect the waste water emits from the operations. Collected wastewater is automatically pumped to the oil/sludge separating tank using a submersible pump. In the separating tank, oil and sludge separated. Separated oil float over the tank surface and sludge collects at the conical bottom part of the tank. Partially treated water enters in to the filter series having two sand filters and an activated carbon filter. Treated water emits at the outlet of the filtering system.

Major Components

- *Initial collection tank (capacity 500 litres)[1]
- * Sludge pump [1]
- * Oil/sludge separator [1]
- * Slow sand filters [2]
- * Activated carbon filter [1]
- * Sludge drying bed [1]
- * Piping and valves

Benefits, to end-users

- *Treated wastewater can be either directly discharged to the environment or recycle back to the washing process.
- *Pre-fabricated, compact unit which can be easily installed and maintained.
- *Comply with the existing regulations for discharging of effluents.

Results

- COD - Reduction of around 86%.
- BOD - Reduction of 80 to 88 %.
- TSS - Reduction of 96-99 %
- pH - within the prescribed limits.
- Oil & Grease - Reduction of 93% to 99%

Contact Details

National Engineering Research and Development Centre, IDB Industrial Estate, Ekala, Ja-Ela, Sri Lanka

Telephone : 0094-11-2236307, 0094-11-2236384 Fax : 0094-11-2233153

E-mail : nerdcentre@nerdc.lk

Web : www.nerdc.lk

Technology Fact Sheet

Technology/Product

Power Weeder

Year

2014

Patent Details

Description of technology



Features of Power Weeder

Power weeder is designed to control weeds in between rows of paddy in low land paddy fields. Specifications of the weeder are as follows;

Rice row gap	6-8 inches
No. of weeding rows	2
Travelling speed	16 m/min
Field Capacity	14 hr/acre
Fuel consumption	6 ltr/acre

General Information

01. Weight	19.5kg
02. Engine capacity	1.25kW
03. Fuel type	Gasoline

Advantages/Benefits

07. Increases rice yield due to aeration to paddy plant
08. Not harmful to the environment and human being
09. Portable
10. Answer to labour scarcity problem
11. Easy to operate & maintenance

Areas of application

Paddy cultivation

Contact Details

National Engineering Research and Development Centre, IDB Industrial Estate, Ekala, Ja-Ela, Sri Lanka

Telephone : 0094-11-2236307, 0094-11-2236384 Fax : 0094-11-2233153

E-mail : nerdcentre@nerdc.lk

Web : www.nerdc.lk

Technology Fact Sheet

Technology/Product

Flood Barrier

Year

2014

Patent Details

Description of technology



Features of Flood barrier

Flood barrier has been designed for minimise/eliminate damages cause by flood to the houses and the industrial premises .

1. Span - Up to 5 ft
2. Height - Maximum 2 ft
3. Galvanised/Aluminium panels
4. Weight – 15 to 20 kg

Advantages/Benefits

1. Minimise damages cause to the houses.
1. Cost effectiveness
2. Easy to fix and remove

Areas of application

- Houses
- Industries
- Other buildings

Contact Details

National Engineering Research and Development Centre, IDB Industrial Estate, Ekala, Ja-Ela, Sri Lanka

Telephone : 0094-11-2236307, 0094-11-2236384 Fax : 0094-11-2233153

E-mail : nerdcentre@nerdc.lk

Web : www.nerdc.lk

Technology Fact Sheet

Technology/Product **Solar Pinatu Dryer**

Year

2016

Patent Details

None

Description of technology



Features of Pinatu Dryer

Pinatu is slabs or sheets of dried palmyrah fruit pulp made on a mat. It is popular in the north & east market because of their unique and attractive flavour, colour and nutritional value. Therefore, Pinatu dryer was developed to hygienically produce Palmyrah fruit leather (Pinatu) for maximum utilization of palmyrah juice.

- Drying area - 39 ft²
- Drying period - 5-6 hrs (depend on sunlight)
- Drying Capacity - 7-10 Kg per batch (for 4 days)
- Type of energy - Direct Solar

General Information

- Height - 3 - 4 ft (with stand)
- Chimney height - 1 m
- Top surfaces fully covered by 5mm thick glass sheet
- Accessories - 2.5*3 ft Stainless Steel food grade trays

Advantages/Benefits

4. Less labour requirement
5. Easy & efficient method
6. Hygienic method

Areas of application

Palmyrah industry

Contact Details

National Engineering Research and Development Centre , IDB Industrial Estate , Ekala , Ja-Ela, Sri Lanka

Telephone : 0094-11-2236307, 0094-11-2236384

Fax : 0094-11-2233153

E-mail : nerdcentre@nerdc.lk

Web : www.nerdc.lk

Technology Fact Sheet

Technology/Product

Slip Form Wall Construction Machine

Year

2017

Patent Details

Patent filed

Description of Technology

Features of Machine



This technology was developed as improvement of existing slip-form wall construction method. Wall construction efficiency has been improved with reduced labour and increased strength. The machine has been developed using electrical vibrator and hydraulic press.

Specifications of the machine are as follows;

1. Compaction strength : 4.9 N/ mm²
2. The average shutter lifting speed: 24mm/second.

Advantages/Benefits

- 1) Portable
- 2) User friendly operation
- 3) Minimization of labour Cost
- 4) special knowledge of skill not required
- 5) high quality finishing of wall

Areas of application

- Building Construction industries

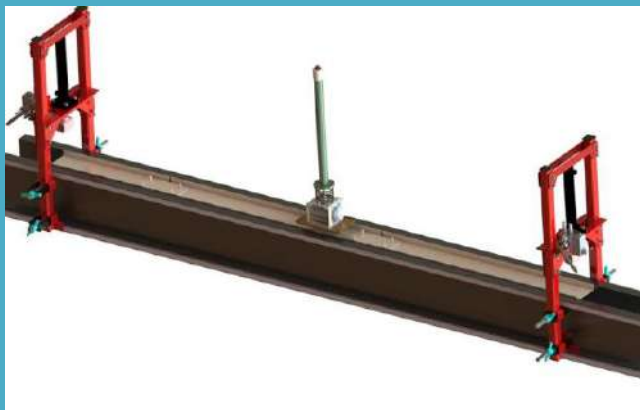

Contact Details

National Engineering Research and Development Centre , IDB Industrial Estate , Ekala , Ja-Ela, Sri Lanka

Telephone : 0094-11-2236307, 0094-11-2236384

Fax : 0094-11-2233153

E-mail : nerdcentre@nerdc.lk

Web : www.nerdc.lk

Technology Fact Sheet

Technology/Product

Temperature Controllable Bakery Oven

Year

2017

Patent Details

None

Description of technology

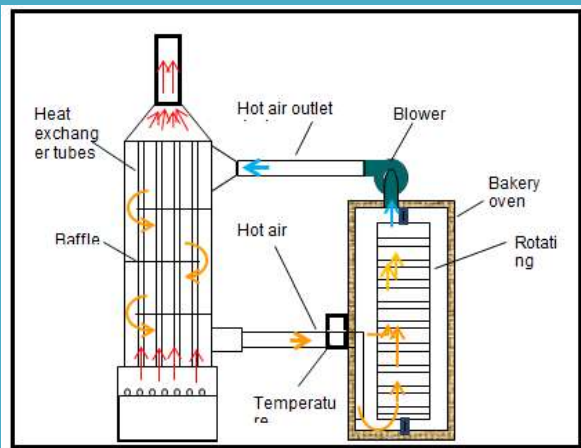

Features of Machine

This Temperature controllable rotary type bakery oven can be used as a substitute for fossil fuel operated one. For quality rice flour bread baking, temperature controllability is very important. This requirement has been achieved by developing this biomass fuelled temperature controllable rotary type bakery oven. Specifications of the machine are as follows;

1. Capacity of the oven - 80 loaves per batch
2. Average baking time - 55 minutes
3. Initial Heating time- 45 minutes
4. Initial set temperature - 240 °C
5. Fuel wood consumption- nearly 20 kg/ batch

Advantages/Benefits

1. Accurate temperature controllability
2. Ability to operate with sustainably grown wood pieces
3. Low specific fuel consumption
4. Portability
5. Avoiding the use of skilled labour for operation
6. All bread trays can be loaded or unloaded once and quickly
7. Reduces open time of heated oven between consecutive batches

Areas of application

- For making breads.
- For making other bakery products.
- For making rice flour bread.

Contact Details

National Engineering Research and Development Centre , IDB Industrial Estate , Ekala , Ja-Ela, Sri Lanka

Telephone : 0094-11-2236307, 0094-11-2236384

Fax : 0094-11-2233153

E-mail : nerdcentre@nerdc.lk

Web : www.nerdc.lk

Technology Fact Sheet

Technology/Product	Domestic Plastic Tank Biogas Digester
Year	2014
Patent Details	None
Description of technology	<p><u>Design Data</u></p> <p>Digester Type : Plastic; capacity 1000litre</p> <p>Maximum daily feed : 4 kg with 6 litres of water</p> <p>Retention time :20 days</p> <p>Gas holder capacity : 200 litres</p> <p>Bio gas from 1 kg kitchen (food waste) : 150 litres</p> <p>Bio gas from 1 kg gliricedia leaves : 75 litres</p> <p><u>Benefits to end user</u></p> <ol style="list-style-type: none"> 1) Provides solutions for household garbage management while providing biogas for cooking and bio slurry as a fertilizer 2) This slurry can also be used as an insect repellent. 3) Organic vegetables can be grown at your home garden using this slurry. <p><u>Major components</u></p> <ol style="list-style-type: none"> 1) 1000 litre capacity plastic digester 2) Gas holder with 225 litre capacity plastic barrel 3) U tube (manometer) 4) Bio gas cooker



Contact Details

National Engineering Research and Development Centre , IDB Industrial Estate , Ekala , Ja-Ela, Sri Lanka

Telephone : 0094-11-2236307, 0094-11-2236384

Fax : 0094-11-2233153

E-mail : nerdcentre@nerdc.lk

Web : www.nerdc.lk

Technology Fact Sheet

Technology/Product

Composite Hollow Core Slab System

Year

2015

Patent Details

None

Description of technology



Features of Composite Hollow Core Slab System

Composite Hollow-Core slab system consists of U-shape pre-stressed concrete beams with 50mm thick insitu concrete topping. These beams contain 6 nos. of 5 mm high tensile steel wires tensioned to 20 kN each. Grade 40 concrete is used to cast the pre-stress beams and the insitu topping is G30 concrete. Insitu topping contains gauge 10, 2"x2" welded G.I. mesh.

General Information

- 1) Available Shapes- "U" shape
- 2) Total thickness-7"
- 3) Size of P.S. Beam 12" x5"

Advantages/Benefits

01. Maximum span is 23'-0"
02. Bottom of the slab is uniform
03. Suitable for higher imposed loads
04. Void can be used to lay service lines

Areas of application

- Slabs with large spans
- Slabs with high imposed loads
- Slabs which need flat soffit

Cost as at 2019

1 sq.ft. – Rs.650.00

Contact Details

National Engineering Research and Development Centre , IDB Industrial Estate , Ekala , Ja-Ela, Sri Lanka

Telephone : 0094-11-2236307, 0094-11-2236384

Fax : 0094-11-2233153

E-mail : nerdcentre@nerdc.lk

Web : www.nerdc.lk

Technology Fact Sheet

Technology/Product

Post Tensioned Masonry Retaining Wall System

Year

2017

Patent Details

None

Description of technology



Features of Post Tensioned Masonry Retaining Wall System

Post Tensioned Masonry Retaining Wall System consists of 6" thk. masonry block work manufactured with 1: 5 cement: quarry dust mortar post-tensioned eccentrically with 5mm H.T.S. steel wires. The Post Tensioned Masonry Retaining Wall is constructed on a insitu concrete foundation and a insitu concrete tie beam is laid at the top of the wall.

General Information

1. Masonry blocks are used
2. Maximum height 10'-0"
3. Thickness of the wall 6"

Advantages/Benefits

1. No vertical formwork and concrete in the wall
2. Light –weight thin precast panels
3. Easy handling and transport
4. Aesthetically pleasing
5. Fast construction
6. simple technique

Areas of application

- Steep slopes
- Road Embankments
- Buildings with level differences

Cost as at 2019

1 sq.ft. – Rs.1,100.00 (including excavation and foundation)

Contact Details

National Engineering Research and Development Centre , IDB Industrial Estate , Ekala , Ja-Ela, Sri Lanka

Telephone : 0094-11-2236307, 0094-11-2236384

Fax : 0094-11-2233153

E-mail : nerdcentre@nerdc.lk

Web : www.nerdc.lk

Technology Fact Sheet

Technology/Product

“L” shaped Prestressed Concrete Steps

Year

2015

Patent Details

None

Description of technology

Features of “L” shaped Prestressed Concrete Steps

“L” shaped Prestressed Concrete Step consists of 2” thk. “L” shaped pre-stressed concrete section which will be supported on precast concrete stringer beam. These steps contains 3 nos. of 5 mm high tensile steel wires tensioned to 20 kN each. Grade 40 concrete is used to cast the pre-stress Concrete Steps.

General Information

1. thickness of the step 2”
2. Maximum span of the step 5’-0”
3. Thread 11”
4. Rise 6”

Advantages/Benefits

1. Cost effective
2. No finishing work required
3. High durability
4. Aesthetically pleasing
5. Fast construction

Areas of application

- Overhead pedestrian crossings
- Externa /Internal stair cases

Cost as at 2019

1 L.ft. – Rs.230.00

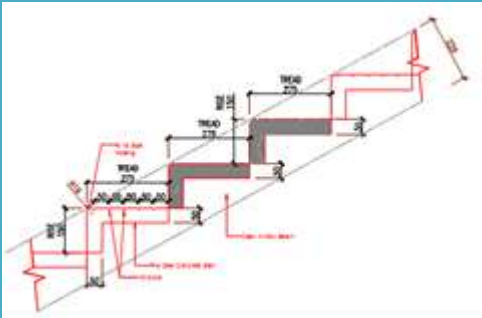

Contact Details

National Engineering Research and Development Centre , IDB Industrial Estate , Ekala , Ja-Ela, Sri Lanka

Telephone : 0094-11-2236307, 0094-11-2236384

Fax : 0094-11-2233153

E-mail : nerdcentre@nerdc.lk

Web : www.nerdc.lk

Technology Fact Sheet

Technology/Product

Hydraulically Operated Compressed Earth Block Machine

Year

2015

Patent Details

None

Description of technology

Features of Hydraulically Operated Semi- Automatic Compressed Earth Block Machine.

Hydraulically Operated Semi-Automatic Compressed Earth Block machine has been designed & developed to be used in mass scale production of earth blocks with inter-locking features of high reliability and dimensional consistency.

1. Production Capacity - 120 blocks /hr.
2. Power Source - 230V, 50 Hz single phase supply
3. Hydraulic Power Pack- 2 Nos. Hydraulic Rams, Hydraulic Double pump, 3 hp-1phase 230V,50Hz Motor, Reservoir tank & Valve box with Solenoid Valve.
4. Control System - Control circuit with relays Contactors, Thermal overload, Limit switches and safety features.

General Information

1. Dimensions(LxWxH) - 936 x 430 x 11345 mm
2. Total weight - 650 kg approximately

Advantages/Benefits

1. High Production capacity
2. Higher quality with better surface finish compared to other blocks produced by other alternative techniques.
3. Dimensional consistency of blocks.
4. User friendly.
5. Operation reliability.
6. High compressive strength.
7. Height of the block could be set as per the user requirement.
8. Minimum labour requirement.

Areas of application

Manufacturing of Compressed Earth Blocks for building construction



Contact Details

National Engineering Research and Development Centre , IDB Industrial Estate , Ekala , Ja-Ela, Sri Lanka

Telephone : 0094-11-2236307, 0094-11-2236384

Fax : 0094-11-2233153

E-mail : nerdcentre@nerdc.lk

Web : www.nerdc.lk

Technology Fact Sheet

Technology/Product

Pre-stressed Concrete Retaining Wall Panels

Year

2016

Patent Details

None

Description of technology

Features of Prestressed Concrete Retaining Wall Panels

Prestressed Concrete Retaining Wall System consists of rectangular shape pre-stressed concrete panels with thicknesses varying from 3" -7" which is fixed on a insitu concrete foundation and a insitu concrete tie beam at the top of the wall. These panels contain maximum of 6 nos. of 5 mm high tensile steel wires tensioned to 20 kN each. Grade 40 concrete is used to cast the pre-stress panels and the insitu concrete foundation is G25 concrete.



General Information

1. Grade 40 concrete is used
2. 5mm HTS wires are used
3. Wires are tensioned to 20kN
4. Timber planks & "C" channels are used as formwork

Advantages/Benefits

1. Thin precast panels
2. Easy handling and transport
3. High durability
4. Aesthetically pleasing
5. Fast construction

Areas of application

- Prestressed concrete retaining walls up to 12'-0"

Cost as at 2019

1 sq.ft. – Rs.1,250.00

Contact Details

National Engineering Research and Development Centre , IDB Industrial Estate , Ekala , Ja-Ela, Sri Lanka

Telephone : 0094-11-2236307, 0094-11-2236384

Fax : 0094-11-2233153

E-mail : nerdcentre@nerdc.lk

Web : www.nerdc.lk

Technology Fact Sheet

Technology/Product

Pre-stressed Concrete Retaining Wall System

Year

2015

Patent Details

None

Description of technology



Features of Prestressed Concrete Retaining Wall System

Prestressed Concrete Retaining Wall System consists of rectangular shape pre-stressed concrete panels with thicknesses varying from 3" -7" which is fixed on a insitu concrete foundation and a insitu concrete tie beam at the top of the wall. These panels contains maximum of 6 nos. of 5 mm high tensile steel wires tensioned to 20 kN each. Grade 40 concrete is used to cast the pre-stress panels and the insitu concrete foundation is G25 concrete.

General Information

1. Minimum space requirement
2. Maximum height 12'-0"
3. Thickness of the panel-7"
4. Size of P.S. Beam 12" x5"

Advantages/Benefits

1. Light –weight thin precast panels
2. Easy handling and transport
3. High durability
4. Aesthetically pleasing
5. Fast construction

Areas of application

- Steep slopes
- Road Embankments
- Buildings with level differences

Cost as at 2019

1 sq.ft. – Rs.1,250.00 (including excavation and foundation)

Contact Details

National Engineering Research and Development Centre , IDB Industrial Estate , Ekala , Ja-Ela, Sri Lanka

Telephone : 0094-11-2236307, 0094-11-2236384

Fax : 0094-11-2233153

E-mail : nerdcentre@nerdc.lk

Web : www.nerdc.lk

Technology Fact Sheet

Technology/Product

Large Scale Hopper Machine

Year

2015

Patent Details

None

Description of technology



Features of Machine

The fully Automated Hopper making machine used to produce hoppers automatically and continuously at high production rates. This is specially developed to use in hotels in high populated areas, tourist hotels etc. Specifications of the machine are as follows;

1. Maximum Output rate -350 hoppers/ hr.
2. Capacity of container - 10 Lit.
3. Type of material -Food grade Stainless steel and Aluminium
4. Power consumption - less than 100W
5. Control system - Operator panel with PLC controlled
6. Movable (mounted on Caster wheels)
7. Washing type – Manual Drain

General Information

1. Size : 5.5 ft x3.5 ft x 3.5 ft.
2. Total weight – 50 kg
3. Heating method : LP Gas

Advantages/Benefits

1. Man power required only for removing hopper.
2. Size of hopper can be controlled as required.
3. Same size and quality for every hopper produced.
4. Less electrical consumption
5. Easy operation
6. Better time saving
7. Attractive in selling hoppers than traditional.

Areas of application

- Hotels & Outdoor functions
- Self-employers
- Tourism Industry
- Many requests from foreign countries.

Contact Details

National Engineering Research and Development Centre , IDB Industrial Estate , Ekala , Ja-Ela, Sri Lanka

Telephone : 0094-11-2236307, 0094-11-2236384

Fax : 0094-11-2233153

E-mail : nerdcentre@nerdc.lk

Web : www.nerdc.lk

Technology Fact Sheet

Technology/Product

Small Scale Milking Machine

Year

2015

Patent Details

None

Description of technology



Features of Machine

This Small Scale Milking machine is used by small scale farmers who have few cows and have no option other than traditional method of milking by hand. Specifications of the machine are as follows;

1. Capacity of tank - 10 Lit.
2. Vacuum Pressure - 50 kPa
3. Average Milking Time – 10 min

General Information

1. Dimensions – 2mx.75mx1m
2. Total weight –
3. Washing method – Manual

Advantages/Benefits

1. Low cost
2. Portable
3. User friendly operation

Areas of application

- Small scale milkers
- Small scale farmers
- Fresh milk collecting centres

Contact Details

National Engineering Research and Development Centre , IDB Industrial Estate , Ekala , Ja-Ela, Sri Lanka

Telephone : 0094-11-2236307, 0094-11-2236384

Fax : 0094-11-2233153

E-mail : nerdcentre@nerdc.lk

Web : www.nerdc.lk

Technology Fact Sheet

Technology/Product

Foot operated water valve

Year

2016

Patent Details

None

Description of technology

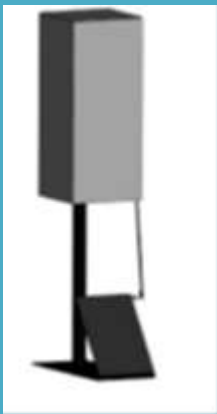

Introduction

This is a new generation water valve use for wash basins which is operated by foot. Pressing the foot paddle by using foot, the water valve of the wash basin is operated. The foot operated water valve contains a complete unit fixed to the floor where the wash basin is fixed meanwhile the water lines of the tap wants to connect through this unit.

General Information:

- Dimensions – 575x250x100 mm
- Total weight – 2kg

Advantages/Benefits

- Save water by 50% compared to the hand operated water valve.
- User friendly design with easy operation.
- Both hands are free for cleaning while operating the tap.
- No requirement of alternative power sources to operate.
- Easy to install and no need heavy modifications for fixing location.
- Can easily control the water flow rate as operator required.
- There is no any affects for the human health.
- Higher durability.
- Less maintenance.
- Ergonomically designed.

Areas of application

- Household, canteens, factories

Contact Details

National Engineering Research and Development Centre , IDB Industrial Estate , Ekala , Ja-Ela, Sri Lanka

Telephone : 0094-11-2236307, 0094-11-2236384

Fax : 0094-11-2233153

E-mail : nerdcentre@nerdc.lk

Web : www.nerdc.lk

Technology Fact Sheet

Technology/Product	Compressed Solid Feed Bale Making Machine
Year	2017
Patent Details	
Description of technology	<p><u>Introduction</u></p> <p>This is used for manufacturing solid feed blocks for cattle. It is a semi-automatic machine and it makes cattle feed blocks using hay and other required nutrients in hygienic manner. These hay blocks can be stored for more than six months and transported very easily because of their square shape and size. Hay blocks can be made especially in ingredients available seasons and they can be used in the dry season as well as rainy season. Introducing this solid feed blocks are resolved issues related to cattle industry such as unavailability of grass lands, storage and transport facility for cattle feeds. These nutrient filled hay blocks directly support to increase milk yield of the cow and ultimately it will support to increase the gross milk production of Sri Lanka.</p> <p><u>Features</u></p> <p>Production Capacity - 100 Blocks/h</p> <ul style="list-style-type: none"> Block size - 200mm*200mm*110mm (Square) Weight of the block - 2kg Raw materials for block- Hay (Straw/Dried leaves) Rice polish/Rice brand, Maize Coconut poonac, Dhal dust Mineral mixture Molasses (Optional) <p><u>General Information;</u></p> <ul style="list-style-type: none"> Dimensions – 7x2x1 m Total weight – 1.5MT Power consumption – 11kW (Three Phase,400V) <p><u>Advantages/Benefits</u></p> <ul style="list-style-type: none"> Semi-automatic operation (Only Manual material loading and unloading is required) Required two persons for production of blocks Making these blocks can reduce the volume of the raw materials 1:10 ratio blocks reduce the transportation and storing cost Blocks can store more than 6 month time period <p><u>Areas of application</u></p> <ul style="list-style-type: none"> Agricultural & livestock



Block Making Machine



Formed Block

Contact Details

National Engineering Research and Development Centre , IDB Industrial Estate , Ekala , Ja-Ela, Sri Lanka

Telephone : 0094-11-2236307, 0094-11-2236384

Fax : 0094-11-2233153

E-mail : nerdcentre@nerdc.lk

Web : www.nerdc.lk

Technology Fact Sheet

Technology/Product

Universal Data Acquisition Module

Year

2018

Patent Details

None

Description of technology

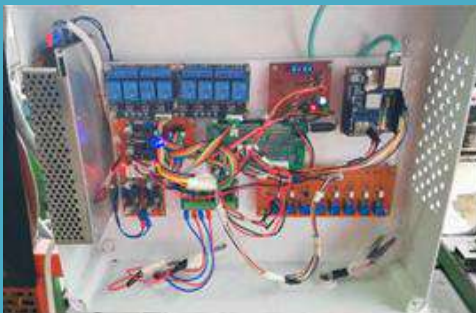

Features of Module

Data Acquisition systems is the process of sampling signals that measure real world physical conditions and converting the resulting samples into digital numeric values that can be manipulated by a PLC, DDC and computer.

Features of the Module are as follows;

1. Support MODBUS protocol with both RTU,TCP/IP configuration
2. Possible 30 RTUs can be connecting via serial communication
3. Available Universal analogue inputs/Outputs
 - Analogue input support 12bit ADC with 0-10V and 4-20 mA
 - Analogue output support 12bit DAC with 0-10V and 4-20 mA
4. Available Digital inputs/outputs
 - Output can be selected by NPN or PNP type
5. Available Relay Output modules

Advantages/Benefits

- Storage of large amount of data
- Customization of data displayed
- Ability to integrate thousands of sensors
- Ability to incorporate advanced control algorithms
- Ability to monitor several types of data
- Ability to view data remotely
- Better consistency of products
- Automatic data logging to free up employees for other tasks
- Automated warning systems

Areas of application

- Fire Systems
- Lighting Control
- Guest room control systems
- Building management Systems

Contact Details

National Engineering Research and Development Centre , IDB Industrial Estate , Ekala , Ja-Ela, Sri Lanka

Telephone : 0094-11-2236307, 0094-11-2236384

Fax : 0094-11-2233153

E-mail : nerdcentre@nerdc.lk

Web : www.nerdc.lk

Technology Fact Sheet

Technology/Product

Bottom ash mixed cement blocks

Year

2016

Patent Details

None

Description of technology

Features of bottom ash mix blocks

Bottom ash is a by-product of burning coal at electricity generation. The large amount of bottom ash is remained at the power plant premises.



General information of wall block

- Achieves min. strength (1.2N/mm²) in 7 days.
- Reduces weight by 20%
- Size -300x100x150 mm

Benefits, to end-users

1. A solution for environmental problem on bottom ash
2. Reduction of fine aggregate consumption (sand, quarry dust)
3. Hence reduce the cost of wall blocks/ Paving block



Contact Details

National Engineering Research and Development Centre , IDB Industrial Estate , Ekala , Ja-Ela, Sri Lanka

Telephone : 0094-11-2236307, 0094-11-2236384

Fax : 0094-11-2233153

E-mail : nerdcentre@nerdc.lk

Web : www.nerdc.lk

Technology Fact Sheet

Technology/Product

Smoked Fish Processing Unit

Year

2017

Patent Details

Patent filed

Description of technology



Features of Smoked Fish Processing Unit

Smoked fish has high consumer demand over salted dried fish and have much potential to develop as small and medium scale industry in Sri Lanka. However, scientific surveys have found that quality of smoked fish products are not in acceptable level. Therefore, improvements in the processing methods of smoked fish are required in order to prevent contamination with unacceptable levels of Polycyclic Aromatic Hydrocarbons (PAH) which are carcinogenic. Due to above reasons, NERD Centre has developed a smoked fish processing unit to minimize PAH contaminations of smoked fish to safe levels.

Capacity - 25-30 kg of fish

Products - Smoked fish (Both marine & inland fish)

*Smoked meat & sausages can also be produced.

Smoking/drying time duration -3hr

Final moisture content of the product - 58-62%

Product shelf life- 14 days in refrigerated conditions (2 ± 1 °C) and
3 months in frozen conditions (-20 ± 1 °C).

General Information

06. Weight – Smoking/drying chamber - 172 kg

Smoke generator - 24kg

Saw dust stove - 11kg

07. Dimensions (LxWxH) - 1800x600x1650mm

08. Fuel used for drying - Saw dust

09. Wood used for smoking - Cinnamon wood

10. All the food touching parts are made using food grade stainless steel

Advantages/Benefits

01. Ability to produce high quality smoked fish

02. Less PAH contamination in smoked fish

03. Easy to control heat and smoke separately

04. Portable unit and can be easily moved using caster wheels in the stand

05. Less fuel usage

06. Easy maintenance

Areas of application

Food industry

Technology Fact Sheet

Technology/Product

Guli making & polishing machine

Year

2018

Patent Details

None

Description of technology



Features of Guli making & polishing machine

As per the requirements of the ayurvedic doctors, guli making and polishing machine was developed and this machine consists of two units; guli making unit and polishing unit. Guli making unit was designed to prepare different sizes of guli (in the range of 3 to 12 mm in diameter) by changing the rollers. Further, both guli making & polishing units of this machine are operated using one motor.

Guli size – 3 to 12mm diameter

General Information

01. Main parts : Guli making unit & Guli polishing unit
02. Space requirement (LxWxH) - 1200 x 750 x 1200mm
03. Weight (approximately) - 108 kg
04. Power requirement - 0.75 kw
05. Rollers & framework are made from 304 stainless steel

Advantages/Benefits

1. Ability to make guli with uniform sizes
2. Ability to make and polish guli in the same machine
3. Ability to change set of rollers for different guli sizes

Areas of application

Ayurvedic industry

Contact Details

National Engineering Research and Development Centre , IDB Industrial Estate , Ekala , Ja-Ela, Sri Lanka

Telephone : 0094-11-2236307, 0094-11-2236384

Fax : 0094-11-2233153

E-mail : nerdcentre@nerdc.lk

Web : www.nerdc.lk

Technology Fact Sheet

Technology/Product

Semi-automated Ayurvedic paste making machine

Year

2018

Patent Details

None

Description of technology



Features of paste making machine

As per the requirements of ayurvedic doctors, semi-automated Paste Making Machine was developed and this machine is suitable for making paste from the herbal powder (containing seed, root, leaves, and particles) mixing with various viscosities liquid to produce cream or paste. Therefore, this is suitable for daily production of herbal paste medicine and paste preparation for other industries

Capacity 2.5kg of / batch

General Information

1. Main parts : stone pestle & motor with speed controller
2. Space requirement (LxWxH) - 750 x 500 x 500mm
3. Weight (approximately) - 88 kg
4. Power requirement - 0.75 kw

Advantages/Benefits

1. Speed can be controlled.
2. Reduce adding liquid level
3. Quality product
4. Limited space requirement

Areas of application

Ayurvedic /food industries

Contact Details

National Engineering Research and Development Centre , IDB Industrial Estate , Ekala , Ja-Ela, Sri Lanka

Telephone : 0094-11-2236307, 0094-11-2236384

Fax : 0094-11-2233153

E-mail : nerdcentre@nerdc.lk

Web : www.nerdc.lk

Technology Fact Sheet

Technology/Product

Coconut Plucking Pole

Year

2018

Patent Details

None

Description of technology



Features of Coconut Plucking Pole

This is a coconut plucking pole made up of two aluminium tubes which are made specially for making poles for plucking various fruits. It is made of low weight, high tensile aluminium alloy used for aircraft industry. This is a good substitute for bamboo plucking poles which are presently scarce.

Features

1. Total length : 16 m(52 ft)
2. Tube size(Diameter) : 45 mm and 38 mm
3. Weight : 8.5 kg

Benefits, to end-users

- Durable
- Resist to environmental conditions
- Low weight
- Adjustable
- No need shelter for storage
- Easy to transport

Contact Details

National Engineering Research and Development Centre , IDB Industrial Estate , Ekala , Ja-Ela, Sri Lanka

Telephone : 0094-11-2236307, 0094-11-2236384

Fax : 0094-11-2233153

E-mail : nerdcentre@nerdc.lk

Web : www.nerdc.lk

Technology Fact Sheet

Technology/Product

Manual Coconut De-husker

Year

2018

Patent Details

None

Description of technology

Features of Manual Coconut De-husker

Generally, coconut de-husking is done manually using a traditional metal/wooden spike in Sri Lanka. Both hands of the de-husker have to be used to detach the husk. This method mainly depends on the skilled and the strength of the de-husker and that is very tedious, tiresome and dangerous. It also requires more time and more energy.

This manual de-husker was designed to make de-husking more comfortable at domestic level. It is a foot operated one and which can operate by an unskilled person without any difficulty.

Features

1. Dimensions (LxWxH) :540x440x735 mm
2. Weight : 11 kg

Benefits, to end-users

- Less effort
 - Safe
 - No need special skills to operate
- Movable



Contact Details

National Engineering Research and Development Centre , IDB Industrial Estate , Ekala , Ja-Ela, Sri Lanka

Telephone : 0094-11-2236307, 0094-11-2236384

Fax : 0094-11-2233153

E-mail : nerdcentre@nerdc.lk

Web : www.nerdc.lk

Technology Fact Sheet

Technology/Product

Smart Parking Monitoring System

Year

2018

Patent Details

None

Description of technology



Design Data

No. of Slots - Up to 100 no. of slots

Sensor units - Ultrasonic

Coverage Distance - 1km

Display control - Raspberry pi

Data transitions to Display- wireless

Benefits, to end-users

1. Save time and energy to both the client and the management.
2. Leads the driver directly and quickly to the available space.
3. Reduce the traffic inside the parks.
4. Decrease the car park management cost.
5. Users stressful situations are minimized.

Major Components

1. Ultrasonic Sensor units
2. Slot status Indicator lamps
3. Vacant slot space identification Entrance Display unit
4. Control Panel with necessary accessories for installation

Characteristics

1. Automatic slot monitoring
2. Indicate occupancy states at the entrance display unit on Graphical User Interface with location.
3. Indicate availability at each slot.
4. Wireless communication between car park and the display unit.
5. Customized system – Modifications can do according to the customer requirement.

Contact Details

National Engineering Research and Development Centre , IDB Industrial Estate , Ekala , Ja-Ela, Sri Lanka

Telephone : 0094-11-2236307, 0094-11-2236384

Fax : 0094-11-2233153

E-mail : nerdcentre@nerdc.lk

Web : www.nerdc.lk

Contacts

Name	Designation	Telephone Numbers	
		Office	Mobile
Eng. D.D.A. Namal	Director General	011-3675575	071-8001900
Eng. G.K.K.A. De Silva	Deputy Director General (R&D)	011-2233150	0773517026
Mr. A.H. Piyasiri	Deputy Director General (S)	011-2234267	0716523186
Eng. A.A.S.P. Jayasinghe	Director- TMD Director – TI	011-2234266	077-3826791
Eng. J.A.A.D. Jayasuriya	HOD- E&EED	011-2233152	071-8001952
Eng. N.G.D. Wijesiriwardane	HOD – E&ED	011-2233151	077-7655100
Eng. J.A.C. Chrishanthi	Director-CED	011-5352253	071-8001968
Eng. K.Y.H.D. Shantha	Director - AE & MD Acting Director – DPD	011-5867603	071-8001937
Eng. K.T. Jayasinghe	HOD – E & ESD	011-5854374	071-8001940
Eng. D.M. Punchibanda	Director - MED	011-2236384 Ext: 354	071-80101967
Mrs. D.V.S. Perera	Director - FD	011-2233149	071-6839682
Ms. D.A.M. Munasinghe	Director - HRD	011-5864909	077-9102789

Abbreviations

Abbreviation	Used for
R&D	Research and Development
S	Services
TMD	Techno Marketing Department
TI	Technology Incubator
HOD	Head of Department
E&EED	Energy & Environmental Engineering Department
E&ED	Electrical & Electronic Department
AE & MD	Agriculture Engineering & Machine Development Department
DPD	Development & Projects Department
E&ESD	Energy & Environmental Services Department
MED	Mechatronics Engineering Department
FD	Finance Department
HRD	Human Resources Department